



MACCHINE SERIGRAFICHE - SILK SCREEN PRINTING MACHINES

Mod. TTP/4



MACCHINA AUTOMATICA A TAVOLA ROTANTE PER LA STAMPA A REGISTRO DI OGGETTI PIANI DI GRANDI DIMENSIONI
AUTOMATIC SCREEN PRINTING MACHINE WITH INDEXED TABLE FOR LARGE OBJECTS WITH FLAT SURFACES ONLY

GPE ARDENGHI Srl

Via Pagazzano, 20 - 24047 TREVIGLIO (BG), ITALY - Tel. ..39/0363.49796 - Fax ..39/0363.301410
Internet : <http://www.gpeardenghi.it> / e-mail : gpe@gpeardenghi.it

CARATTERISTICHE - TECHNICAL FEATURES

DISCO TAVOLA CON 4 POSIZIONI

DIMENSIONI MAX. OGGETTI

CORSA DI STAMPA UTILE MAX.

PRODUZIONE ORARIA

CARICO MANUALE

POSSIBILITÀ DISPOSITIVO ANTISTATICO

STAZIONE DI STAMPA COMPLETA

SISTEMA NO-OBJECT NO-PRINT

POSSIBILITÀ DI SCARICO AUTOMATICO

CABINATURA DI SICUREZZA

Ø mm 1300

mm 650X90/400X265/320X320 H 100

mm 650

500 - 1500

FZ

SC

NP

YA

LR

INDEXED TABLE WITH 4 STATIONS

MAX. SIZES OF OBJECTS

MAX. AVAILABLE PRINTING STROKE

OUTPUT PER HOUR

MANUAL LOADING

DEIONIZING DEVICE (OPTIONAL)

COMPLETE PRINTING STATION

NO-OBJECT NO-PRINT SYSTEM

AUTOMATIC DISCHARGING SYSTEM (OPTIONAL)

SAFETY CABINET

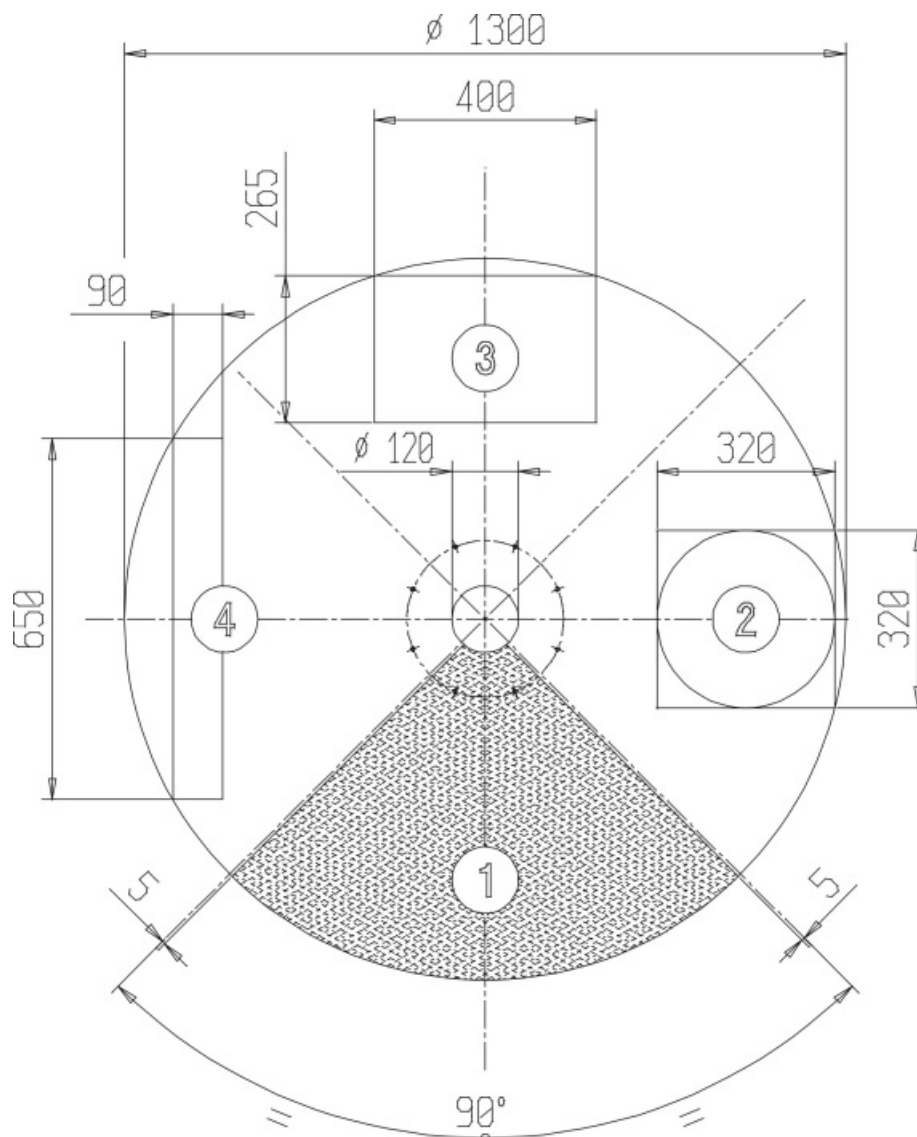

 *Ingombro per alloggiamento oggetti*

GPE ARDENGHI Srl

Via Pagazzano, 20 - 24047 TREVIGLIO (BG), ITALY - Tel. ..39/0363.49796 - Fax ..39/0363.301410

Internet : <http://www.gpeardenghi.it> / e-mail : gpe@gpeardenghi.it