

# Pad printing machine with automatic pad cleaning

■ Precision engineered for superior quality printing

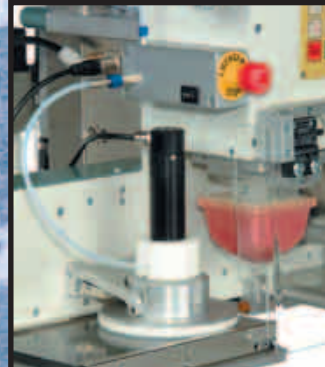

X-Y-R Plateadjustment



Viscomatic

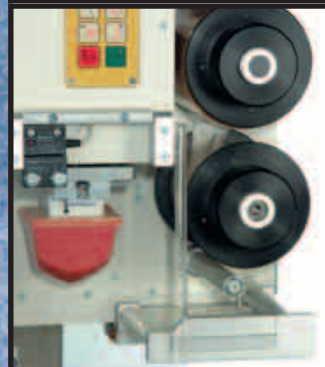

Automatic padcleaning

- Easy set-up and change-over
- Fully integrated automatic pad cleaning
- Fully-automatic ink viscosity control (optional)
- Built with first class components for long life
- Worldwide Service and Support



microPrint  
SWITZERLAND

# Pad printing machine

## with automatic pad cleaning

PAD PRINTING MACHINE  
**LCN 130**

The LCN 130 is a compact and robust padprinting machine that has been fine-tuned for performance.

The LCN 130 is very reliable and simple to operate, and it works well as a stand-alone printer or is easily integrated into automated systems. In building all microPrint machines we use

only top quality world class components and our workmanship is unparalleled.

### Worldwide service

All microPrint machines come complete with our worldwide customer service network and are backed with a **3 year** limited warranty.



### Technical data

Printing capacity:	up to 2100/hr
Drive:	pneumatic
Printing force:	max. 450 N
Compressed air supply:	5–6 bar (87 psi)
Air consumption:	1,8 l/cycle
Control system:	PLC
Main voltage:	110 – 240 V 50–60Hz.
Control voltage:	24 VDC
Weight Modul:	31 kg.
Weight Stand:	20 kg.
Dimensions:	see illustration
Plate size:	130 x 100 mm 130 x 230 mm
Platethickness:	0.5 or 10 mm
Cup size Ø 86 mm:	Print Ø 76 mm
Cup size Ø 120 mm:	Print 70 x 110 mm

also available with open inkwell upon special request

### Module

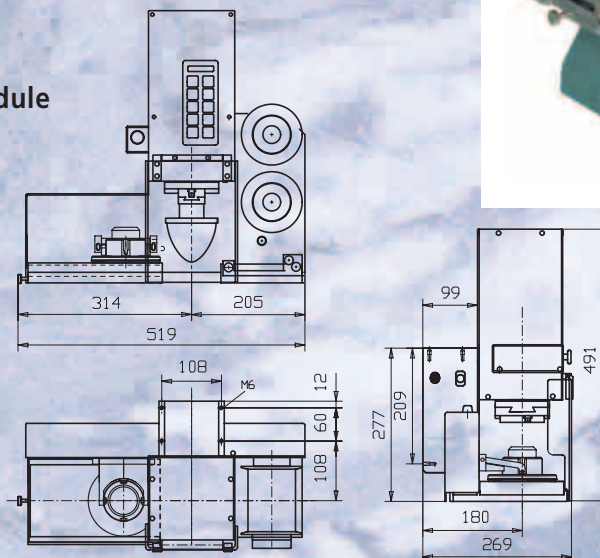

### Stand

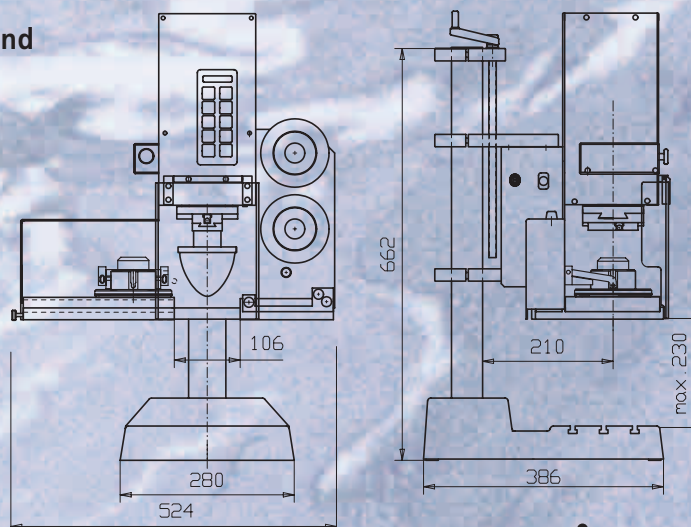

### Info

We keep you informed with our home page <http://www.microprint.ch> about our newest developments. You will also find useful information about padprinting.



**microPrint**  
SWITZERLAND

**microPrint LC GmbH**  
Mühlentalstrasse 184  
CH-8200 Schaffhausen  
Switzerland

Phone: + 41 (0) 52 624 50 59  
Fax: + 41 (0) 52 624 50 22  
E-mail: [info@microprint.ch](mailto:info@microprint.ch)  
[http:// www.microprint.ch](http://www.microprint.ch)